

20 Litre / 5 USG Rectangular (Swing Handle) Tight Head (Y1.9)

077 series

Mold Number(s): 977A/B

A 20L, heavy duty rectangular tight head made of High Density Polyethylene. The package is ideal for use as a shipping container for a wide range of Chemicals and numerous general uses.

PERFORMANCE SPECIFICATIONS

- No objection status for food contact applications from the Health Protection Branch in Canada and compliance for use in food contact applications by the Food and Drug Administration in the United States. Black tight heads excluded.
- UN Classification for transportation or Group II or III liquids with specific gravity up to 1.9 when used in conjunction with 70mm Rieke FS70 or FS70TE closure.

DIMENSIONS

Capacity

Rated 20 L

Overflow 20.5 L

Weight

Container Only 1200 gm ± 25

Dimensions

L x W x H 10.75" x 9.88" x 16"

Panel Dimensions

Sides W X H 6.5" X 14"

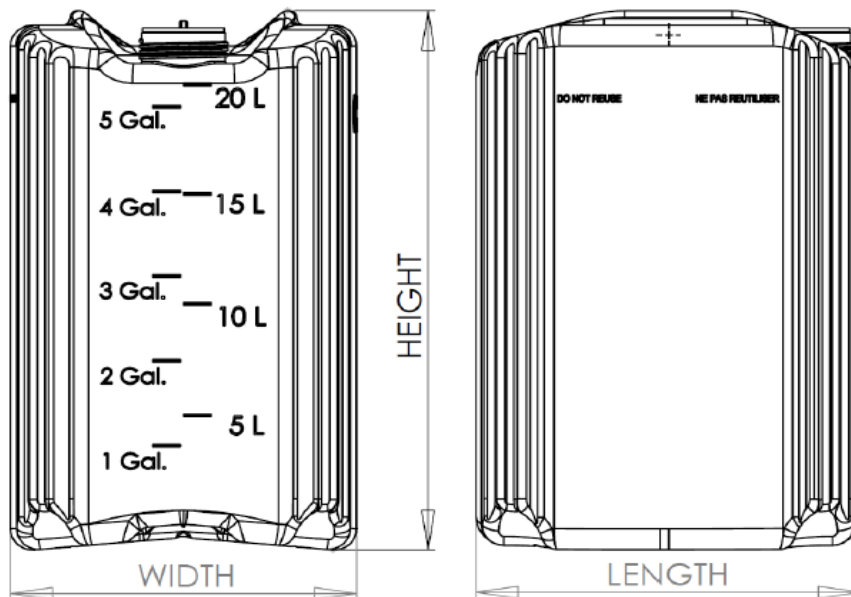

SPECIAL FEATURES

Neck Finish	Neck is designed to accommodate Rieke's 70mm TE and non TE closure
Venting	Available with or without 18mm vent at rear of container, capped or uncapped. End user may puncture vent to minimize glugging during pouring.
Decorating	Tight head is flamed to improve adhesion of labels and inks.
Stacking	Tight heads nest together to improve stability during storage.
Handle	A comfortable handle attached to the top of the tight head to aid in handling and for ease of pouring.

FILLING AND STACKING RECOMMENDATIONS

- Compatibility of the bottle with the fill product is the responsibility of the filler.
- Contents should not exceed 70°C (158°F) at time of fill.
- Filled containers should not be stacked and stored above 50°C (122°F).

For **Stacking Recommendations** please contact Reliance Products.

PACKAGING AND SHIPPING DATA

Quantity per Pallet	Bulk 60 pieces
Package Weight	167 lbs. + 40 lbs. for pallet
Shipping Dimensions (L x W x H)	49" x 38" x 48"
Shipping Volume (Cubic Feet)	51
Truck Load Quantity	3360 pieces

WARRANTY

Reliance Products Ltd warrants product to meet the above specifications and to be free from defect in workmanship and materials at time of shipment. *Liability is limited to the replacement cost of the containers purchased. Reliance Products Ltd does not test specific product packaging requirements and as such, customers are required to assure packaging meets the legal, environmental and containment needs of the product being packaged.*



CONTACT US FOR ALL YOUR PACKAGING NEEDS

sales@relianceproducts.com / 1.800.665.0258

www.relianceproducts.com